

## DEHUMIDIFICATION AND VENTILATION FOR RESIDENTIAL AND LIGHT COMMERCIAL RADIANT SYSTEMS



HiDew is proud to present a complete range of dehumidifiers for radiant cooling systems and high performance heat recovery systems for the residential Controlled Mechanical Ventilation and light commercial.

Every HiDew dehumidifier and recovery system has been designed to respond to an increasingly demanding market in terms of technology, reliability, design, compactness, efficiency, sound level, simplicity and installation ease.

A wide range of accessories (optional) can fulfil any request and, in the event that installation is especially difficult, HiDew technicians are available to suggest and provide customized solutions.

## QUALITY FOR YOUR WELLBEING

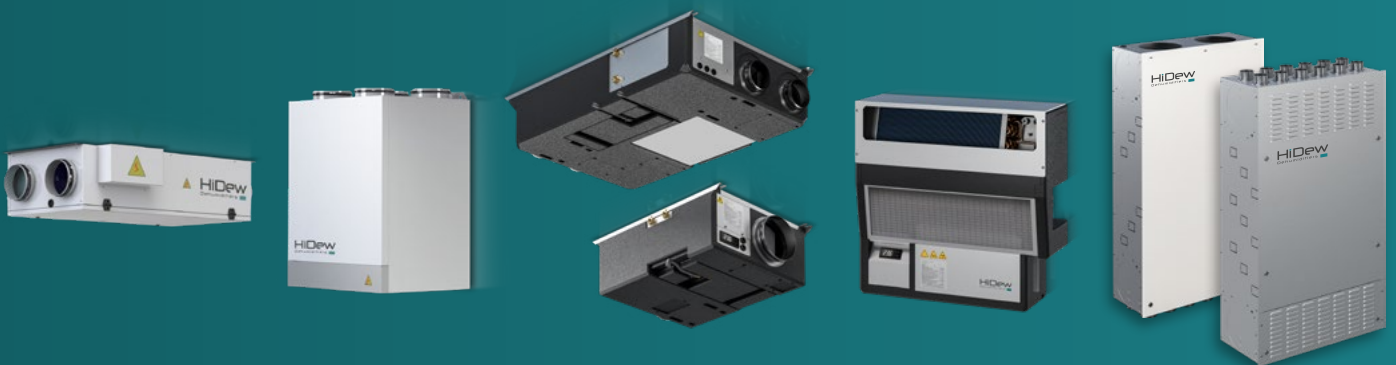

# HiDew

Dehumidifiers

Horizontal polypropylene dehumidifiers for radiant systems



**RO**

P. 4

Horizontal dehumidifiers for radiant systems



**RS**

P. 6

Vertical polypropylene dehumidifiers for radiant systems



**RV**

P. 8

Horizontal polypropylene dehumidifiers with heat recovery for radiant systems



**HO**

P. 10

Horizontal dehumidifiers with heat recovery for radiant systems



**RER**

P. 12

Vertical dehumidifiers with heat recovery for radiant systems



**REV**

P. 14

Horizontal and vertical polypropylene heat recovery units



**RDE**

P. 16

Built-in vertical heat recovery units



**RCE**

**RFE**

P. 18

Heat recovery units



**RVE**

**ROE**

P. 22

Air-to-Air system for passive houses with heat recovery



**AER**

P. 24

Devices for air ducting



**AIR  
DISTRIBUTION**

P. 26



**RO**

**HORIZONTAL POLYPROPYLENE DEHUMIDIFIERS FOR RADIANT SYSTEMS**



RO series horizontal ducted ceiling-mounted polypropylene dehumidifier are designed for use in civil, residential and commercial environments (the latter being small in size) with high latent load, where 24 h/day operation is required. These are particularly suitable for buildings cooled by radiant systems, such as floors, walls or ceiling. HiDew dehumidifiers can be connected and supervised with Modbus RS485 serial port. R-513a refrigerant gas is used in RO unit.

Datasheet		RO 20 A	RO 20 I	RO 25 A	RO 25 I
Dehumidifying capacity	L/Day	16	16	25	25
Nominal air flow	m³/h	200	200	260	260
Available static pressure (high pressure)	Pa	40 (260)	40 (260)	40 (230)	40 (230)
Cooling capacity	W	0	1356	0	1818
Sound level	dB(A)	37	37	39	39
Power supply	V/ph/Hz	230 / 1~ +N / 50			
Dimensions W x D x H	mm	710 x 515 x 250			
Weight	kg	24	26	24	26

Datasheet		RO 30 A	RO 30 I	RO 35 A	RO 35 I
Dehumidifying capacity	L/Day	28	28	32	32
Nominal air flow	m³/h	300	300	350	350
Available static pressure (high pressure)	Pa	40 (200)	40 (200)	40 (170)	40 (170)
Cooling capacity	W	0	2069	0	2425
Sound level	dB(A)	40	40	42	42
Power supply	V/ph/Hz	230 / 1~ +N / 50			
Dimensions W x D x H	mm	710 x 515 x 250			
Weight	kg	26	28	26	28

All the values refer to the following conditions: Air temperature 26°C, relative humidity 65%, water temperature 15°C.

**RO** dehumidifiers are provided with 3-speeds EC radial fan for maximum silence and running efficiency.

If a higher prevalence is required, the RO models can be provided with modulating EC radial fan.

Finally, a centrifugal fan with ACF (Automatic Control Flow) is available: in this case, the unit self-adjusts the speed of the fans to keep the rated flow rate unchanged, a useful function when installing and/or fouling filters.

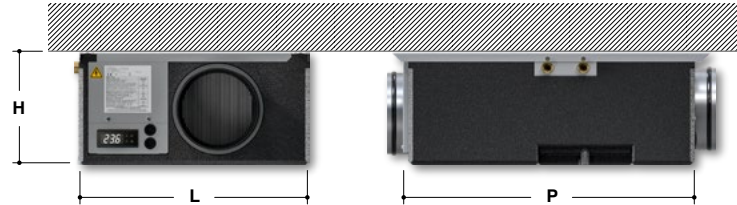

**The RO range consists of 2 versions : A – I**

**A = Neutral air (isothermal) version:** the letter “A” represents the neutral air isothermal dehumidifier.

The outlet air is at the same temperature as the inlet air.

**I = Cold integration version:** The letter “I” represents the dehumidifier that can add cold capacity to the radiant system.

The “I” models cool the air when required, just as a normal air-conditioner.

**Standard with basic control:**

- On-board graphic display
- Supply nozzle
- 3-speeds EC radial fan (low prevalence)
- Filter class ISO Coarse 70% (G2)
- Modbus RS485 serial communication
- Alarms signaling



**Standard with Touch control:**

- Supply nozzle
- Modulating EC radial fan (high prevalence)  
(option for basic control)
- Filter class ISO Coarse 70% (G2)
- T/RH touch display connection cable of 2 meters
- Modbus RS485 serial communication
- Dew point control
- Time bands program
- Alarms signaling



**Options:**

- Supply nozzle
- Suction temperature probe
- Suction humidity probe
- Temperature probe on board (version I)
- Hygrostat
- Centrifugal fan with ACF
- 0-10 V input for modulating EC radial fan
- Filter class ISO Coarse 90% (G4), filter class ISO ePM10 80% (F7)
- T/RH touch display connection cable of 5, 10 or 20 meters
- Filter access from the top
- Anti-vibration rubbers
- Compressor soundproofing
- Air distribution: see chapter AIR DISTRIBUTION

**RS**

**HORIZONTAL DEHUMIDIFIERS FOR RADIANT SYSTEMS**

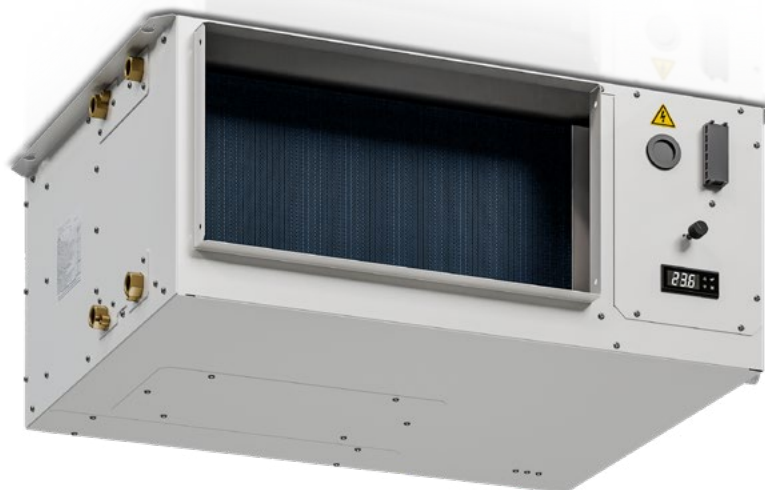

**RS 050**

- R-513a**  
OZONE FRIENDLY
- R-410a**  
OZONE FRIENDLY
- DEHUMIDIFICATION
- COOLING
- LOW NOISE
- ISOTHERMIC
- RS485**  
PROTOCOL  
CONNECTION LINK
- AIR FILTERS

Horizontal ducted ceiling-mounted **RS** series dehumidifiers are designed for use in civil, residential and commercial environments with high latent load where 24 h/day operation is required.

These are particularly suitable for buildings cooled by radiant systems, such as floors, walls or ceiling.

HiDew dehumidifiers can be connected and supervised with Modbus RS485 serial port.

R-513a refrigerant gas is used for **RS 050** units.

R-410a refrigerant gas is used for **RS 100** units.

Datasheet		RS 050 A	RS 050 I	RS 100 A	RS 100 I
<b>Dehumidifying capacity</b>	L/Day	48	48	100	100
<b>Nominal air flow</b>	m³/h	600	600	1000	1000
<b>Available static pressure</b>	Pa	150	150	150	150
<b>Cooling capacity</b>	W	/	3360	/	6800
<b>Sound level</b>	dB(A)	43	43	46	46
<b>Power supply</b>	V/ph/Hz	230 / 1~ +N / 50			
<b>Dimensions W x D x H</b>	mm	760 x 650 x 350		1000 x 600 x 450	
<b>Weight</b>	kg	52	55	80	82

All the values refer to the following conditions: Air temperature 26°C, Relative humidity 65%, Water temperature 15°.

The **RS** dehumidifiers are provided with EC electronic fan, adjustable air flow by potentiometer.

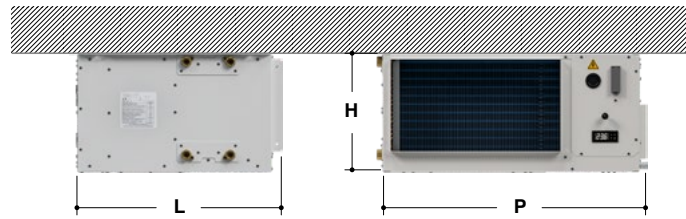

The **RSE** range consists of two versions : **A – I**

**A = Neutral air version (isothermal):** The letter “A” represents the neutral air isothermal dehumidifier with air condensation. The outlet air is at the same temperature as the inlet air.

**I = Cold integration version:** The letter “I” represents the dehumidifier that can add capacity power to the radiant system. The “I” models cool the air when required, just as a normal air-conditioner.

**Included:**

- On-board graphic display
- Temperature probe on board (version I)
- Brushless electronic fans with adjustable flow rate
- Alarms signaling
- Automatic defrosting



**Options:**

- Mechanical wall-mounted hygrostat
- Mechanical humidistat for in-wall installation
- Two-steps hygrostat
- Chrono-Thermo hygrostat summer/winter
- Touch display with T/RH probes (available from 2025)
- Kit frame for suction ducting
- High efficiency filter
- Serial board RS485 - Modbus
- Supply plenum
- Air distribution: see chapter AIR DISTRIBUTION



**RV**

**VERTICAL POLYPROPYLENE DEHUMIDIFIERS FOR RADIANT SYSTEMS**

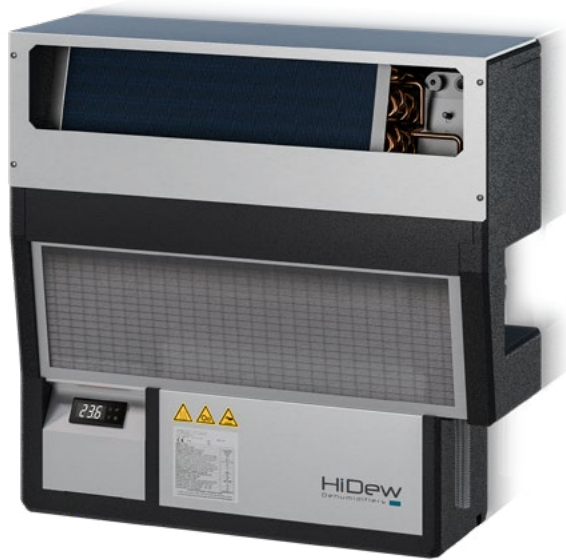

**RV** series vertical wall-mounted polypropylene dehumidifiers are designed for use in civil, residential and commercial environments (the latter being small in size) with high latent load, where 24 h/day operation is required. These are particularly suitable for buildings cooled by radiant systems, such as floors, walls or ceiling. HiDew dehumidifiers can be connected and supervised with Modbus RS485 serial port. R-513a refrigerant gas is used in **RV** unit.

Datasheet		RV 20 A	RV 20 I	RV 25 A	RV 25 I
Dehumidifying capacity	L/Day	16	16	25	25
Nominal air flow	m³/h	200	200	260	260
Cooling capacity	W	0	1356	0	1818
Sound level	dB(A)	35	35	37	37
Power supply	V/ph/Hz	230 / 1~ +N / 50			
Dimensions W x D x H	mm	730 x 250 x 715			
Weight	kg	24	26	24	26

Datasheet		RV 30 A	RV 30 I	RV 35 A	RV 35 I
Dehumidifying capacity	L/Day	27	27	30	30
Nominal air flow	m³/h	300	300	350	350
Cooling capacity	W	0	2069	0	2425
Sound level	dB(A)	38	38	40	40
Power supply	V/ph/Hz	230 / 1~ +N / 50			
Dimensions W x D x H	mm	730 x 250 x 715			
Weight	kg	26	28	26	28

All the values refer to the following conditions: Air temperature 26°C, Relative humidity 65%, Water temperature 15°C.

**RV** dehumidifiers are provided with three-speeds EC radial fan for maximum silence and operating efficiency. If a higher head is required, the RV models can be provided with modulating EC tangential fan.

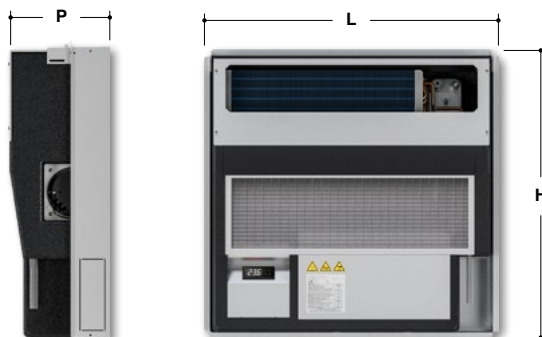

The RV range consists of two versions : **A – I**

**A = Neutral air version (isothermal):** The letter “A” represents the neutral air isothermal dehumidifier with air condensation. The outlet air is at the same temperature as the inlet air.

**I = Cold integration version:** The letter “I” represents the dehumidifier that can add capacity power to the radiant system. The “I” models cool the air when required, just as a normal air-conditioner.

**Standard with basic control:**

- EC tangential fan with 3 speeds
- Filter class ISO Coarse 70% (G2)
- Modbus RS485 serial communication



**Standard with Touch control:**

- EC modulating tangential fan (option for basic control)
- Filter class ISO Coarse 70% (G2)
- T/RH touch display connection cable of 2 meters
- Modbus RS485 serial communication
- Dew point control



**Options:**

- Suction temperature probe
- Suction humidity probe
- Hygrostat
- 0-10 V input for modulating EC radial fan
- T/RH touch display connection cable of 5, 10 or 20 meters
- Compressor soundproofing
- Slim formwork (semi-recessed) and aesthetic slim cover
- Standard formwork (recessed) and cover panel
- Cover cabinet (cantilever installation) and cover panel



**HO**

**HORIZONTAL POLYPROPYLENE DEHUMIDIFIERS WITH HEAT RECOVERY FOR RADIANT SYSTEMS**

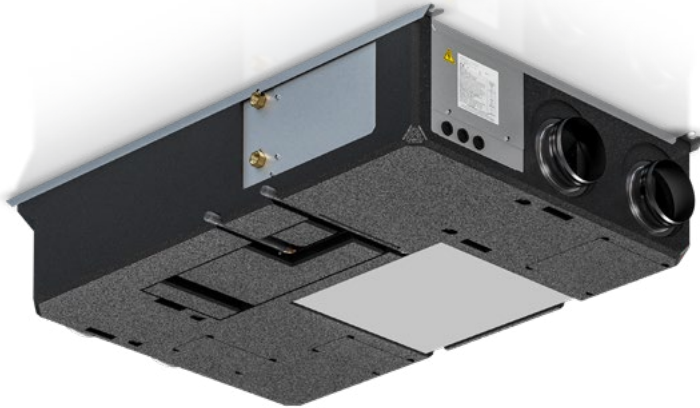

The **HO** series dehumidifiers with a very high efficiency heat recovery unit are designed for use in buildings with radiant cooling where air exchange is provided in addition to dehumidification.

In fact, HO dehumidifiers can dehumidify, cool, heat, and exchange air by recovering heat from the expelled air.

Modulating EC radial fans provide high prevalence and optimize power consumption.

The use of top-quality components in refrigeration, hydraulic, aerualic and electrical components make HO units state-of-the-art dehumidifiers in terms of efficiency, reliability and quiet operation.

The ultra-high-efficiency cross-flow heat recuperator guarantees efficiencies of over 85%, and it is also possible to set the fresh air rate in 5 steps.

It's possible to manage the units through home automation thanks to the standard Modbus RS485 connection.

R-513a refrigerant gas is used in **HO** unit.

**Datasheet**

		<b>HO 20 A</b>	<b>HO 20 I</b>	<b>HO 20 W</b>	<b>HO 25 A</b>	<b>HO 25 I</b>	<b>HO 25 W</b>
<b>Dehumidifying capacity</b>	L/Day	16	16	22	25	25	29
<b>Nominal air flow</b>	m³/h	200	200	200	260	260	260
<b>Fresh air flow</b>	m³/h	0-100	0-100	0-100	0-130	0-130	0-130
<b>Available static pressure</b>	Pa	260	260	260	230	230	230
<b>Heat recovery efficiency</b>	%	Up to 91%			Up to 90%		
<b>Cooling capacity</b>	W	0	1356	1490	0	1818	1880
<b>Sound level</b>	dB(A)	37	37	36	39	39	38
<b>Power supply</b>	V/ph/Hz	230 / 1~ +N / 50					
<b>Dimensions W x D x H</b>	mm	1130 x 740 x 250					
<b>Weight</b>	kg	34	36	28	34	36	28

**Datasheet**

		<b>HO 30 A</b>	<b>HO 30 I</b>	<b>HO 30 W</b>	<b>HO 35 A</b>	<b>HO 35 I</b>	<b>HO 35 W</b>
<b>Dehumidifying capacity</b>	L/Day	28	28	34	32	32	38
<b>Nominal air flow</b>	m³/h	300	300	300	350	350	350
<b>Fresh air flow</b>	m³/h	0-150	0-150	0-150	0-175	0-175	0-175
<b>Available static pressure</b>	Pa	200	200	200	250	250	250
<b>Heat recovery efficiency</b>	%	Up to 89%			Up to 88%		
<b>Cooling capacity</b>	W	0	2069	2160	0	2425	2470
<b>Sound level</b>	dB(A)	40	40	39	42	42	41
<b>Power supply</b>	V/ph/Hz	230 / 1~ +N / 50					
<b>Dimensions W x D x H</b>	mm	1130 x 740 x 250					
<b>Weight</b>	kg	36	38	28	36	38	28

All the values refer to the following conditions: Air temperature 26°C, relative humidity 65%, water temperature 15°C W version: water at 10°C

**The HO range consists of 3 versions : A – I - W**

**A = Neutral air (isothermal) version:** the outlet air is dehumidified and at the same temperature as the inlet air.

**I = Cold integration version:** The letter “I” represents the dehumidifier that can add cold capacity to the radiant system.

**W = Water version:** The letter “W” identifies an especially silent chilled water hydronic dehumidifier without compressor. The outlet air is always cooler than the inlet air. The “W” version can heat the air in winter.

**Summer functions**

- Renewal
- Renewal + dehumidification
- Renewal + dehumidification + cooling
- Dehumidification
- Dehumidification + cooling
- Free-cooling

- |                                       |                             |
|---------------------------------------|-----------------------------|
| 1 Fresh air intake                    | 9 Exhaust fan               |
| 2 Exhaust air intake                  | 10 Heat recovery system     |
| 3 Room air intake (for recirculation) | 11 Recirculation damper     |
| 4 Exhaust air discharge               | 12 Recirculation air filter |
| 5 Room air supply                     | 13 Extraction air filter    |
| 6 Heat exchange coil                  | 14 Fresh air filters        |
| 7 Blower fan                          | 15 Fresh air damper         |
| 8 Compressor                          |                             |

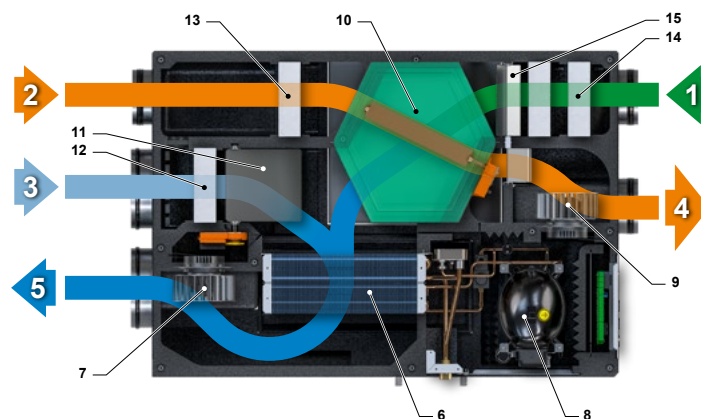

**Winter functions**

- Renewal
- Renewal + heating
- Heating
- Free-heating

**Included:**

- Color touch display with T/RH probes with cable connection 2 meters
- Modulating EC radial fan
- Filter: Recirculation class ISO Coarse 70% (G2) Outside air class ISO Coarse 70% (G2), Extraction class ISO Coarse 70% (G2)
- Modbus RS485 serial communication
- Dew point control
- Time bands program
- Multi-speed fresh air
- Timed signaling for filter control
- Boost mode for fresh air



**Options:**

- |  |   |
|--|---|
| <ul style="list-style-type: none"> <li>- Touch display with T/RH/IAQ probes and Wi-fi with 2 meters connection cable</li> <li>- T/RH probes on board</li> <li>- Filter class ISO Coarse 90% (G4), filter class ISO ePM10 80% (F7)</li> <li>- T/RH touch display connection cables of 5, 10 or 20 meters</li> <li>- Filter access from the top</li> <li>- Dew point control with outside air dampers</li> </ul> | <ul style="list-style-type: none"> <li>- Free-cooling</li> <li>- Enthalpic recuperator</li> <li>- Automatic recuperator defrosting</li> <li>- Compressor soundproofing</li> <li>- Supply air temperature control kit</li> <li>- Anti-vibration rubbers</li> <li>- Air distribution: see chapter AIR DISTRIBUTION</li> </ul> |
|--|---|

**RER**

**HORIZONTAL DEHUMIDIFIERS WITH HEAT RECOVERY FOR RADIANT SYSTEMS**



**RER 050**

The **RER** range dehumidifiers with high-efficiency heat recovery system are used in radiant cooling buildings together with an air renewal system.

The RER dehumidifiers dehumidify, cool, heat and change the air by recovering heat from the expelled air.

High pressure and minimum electric consumptions are guaranteed by the adjustable electronic fans brushless motor.

The top-quality refrigeration, hydraulic, aerualic and electrical components make RER units state of the art dehumidifiers in terms of efficiency, reliability and silence.

More than 90% yield is guaranteed by the high-efficiency cross-flows heat recovery.

The modulating air renewal can be manual or automatic.

Temperature and humidity sensors are included, thus making the dehumidifier completely autonomous in regulation.

The RER dehumidifiers can be connected to a home automation system thanks to the RS485 serial port and more than 100 editable parameters.

R-513a refrigerant gas is used for **RER 050** unit.

R-410a refrigerant gas is used for **RER 100** unit.

**Datasheet**

		<b>RER 050 A</b>	<b>RER 050 I</b>	<b>RER 050 W</b>	<b>RER 100 A</b>	<b>RER 100 I</b>	<b>RER 100 W</b>
<b>Dehumidifying capacity</b>	L/Day	48	48	58	100	100	120
<b>Nominal air flow</b>	m³/h	520	520	520	1000	1000	1000
<b>Fresh air flow</b>	m³/h	0-250	0-250	0-250	0-500	0-500	0-500
<b>Heat recovery efficiency</b>	%	> 90%			> 90%		
<b>Cooling capacity</b>	W	Isotermico	3230	3650	Isotermico	6800	7700
<b>Sound level</b>	dB(A)	44	44	43	47	47	44
<b>Power supply</b>	V/ph/Hz	230 / 1~ +N / 50					
<b>Dimensions W x D x H</b>	mm	1665 x 760 x 375			1500 x 1120 x 450		
<b>Weight</b>	kg	80	80	70	140	140	130

All the values refer to the following conditions: Air temperature 26°C, Relative Humidity 65%, Water temperature 15°C W Version: water at 10°C

**The RER range consists of 3 versions : A – I - W**

**A = Neutral air version (isothermal):** The letter “A” represents a neutral air isothermal dehumidifier. The outlet air is at the same temperature as the inlet air.

**I = Cold integration version:** The letter “I” represents a dehumidifier that can add cold power to the radiant system. The “I” models cool the air as a normal air-conditioner, when required.

**W = Water version:** The letter “W” identifies an especially silent chilled water hydronic dehumidifier without compressor. The outlet air is always cooler than the inlet air. The “W” version supplies conditioned air in summer and heating in winter.

**Summer functions**

- Renewal
- Renewal + dehumidification
- Renewal + dehumidification + cooling
- Dehumidification
- Dehumidification + cooling
- Free-cooling

- |                                       |                               |
|---------------------------------------|-------------------------------|
| 1 Fresh air intake                    | 9 Exhaust fan                 |
| 2 Exhaust air intake                  | 10 Heat recovery system       |
| 3 Room air intake (for recirculation) | 11 Recirculation damper       |
| 4 Exhaust air discharge               | 12 Supply air filter          |
| 5 Room air supply                     | 13 Recovery system air filter |
| 6 Heat exchange coil                  | 14 Outdoor air filter         |
| 7 Supply fan                          | 15 Outdoor air damper         |
| 8 Compressor                          |                               |

**Winter functions**

- Renewal
- Renewal + heating
- Heating
- Free-heating

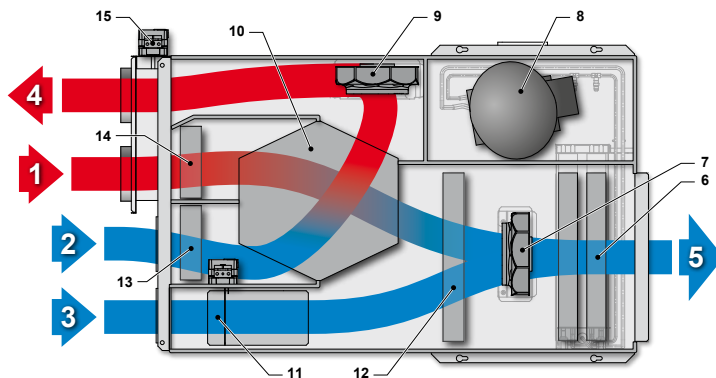

**Included:**

- Color touch display with T/RH probes + 2 meters connection cable
- Modulating EC fan
- Filter: Recirculation class ISO Coarse 70% (G2) Outside air class ISO Coarse 70% (G2), Extraction class ISO Coarse 70% (G2)
- Serial board RS485 - Modbus
- Time bands program
- Multi-speed fresh air
- Timed signal for air filters check
- Boost mode for fresh air



**Options:**

- |  |   |
|--|---|
| <ul style="list-style-type: none"> <li>- Color touch display with T/RH/IAQ probes and WiFi + 2 meters connection cable</li> <li>- Outdoor air dampers for dew-point control</li> <li>- Free-cooling</li> <li>- ACF - Automatic Control Flow</li> <li>- T/RH touch display connection cables of 5, 10 or 20 meters</li> <li>- Temperature and humidity probes on board</li> <li>- Enthalpic recuperator</li> <li>- Filter class ISO Coarse 90% (G4), filter class ISO ePM10 80% (F7)</li> </ul> | <ul style="list-style-type: none"> <li>- T/RH probes on board</li> <li>- Recovery automatic defrosting</li> <li>- Serial board RS485 - Modbus</li> <li>- Silent version</li> <li>- Adjustable supply air temperature control</li> <li>- Supply plenum</li> <li>- Extraction plenum</li> <li>- Recirculation plenum</li> <li>- Air distribution: see chapter AIR DISTRIBUTION</li> </ul> |
|--|---|

**REV**

**VERTICAL DEHUMIDIFIERS WITH HEAT RECOVERY FOR RADIANT SYSTEMS**



REV 020



REV 050

The **REV** range dehumidifiers with high-efficiency heat recovery system are used in radiant cooling buildings together with an air renewal system.

The REV dehumidifiers dehumidify, cool, heat and change the air by recovering heat from the expelled air.

High pressure and minimum electric consumptions are guaranteed by the adjustable electronic fans brushless motor.

The top-quality refrigeration, hydraulic, aeraulic and electrical components make REV units state of the art dehumidifiers in terms of efficiency, reliability and silence.

More than 90% yield is guaranteed by the high-efficiency cross-flows heat recovery.

The modulating air renewal can be manual or automatic.

Temperature and humidity sensors are included, thus making the dehumidifier completely autonomous in regulation.

The REV dehumidifiers can be connected to a home automation system thanks to the RS485 serial port and more than 100 editable parameters. R-513a refrigerant gas is used in **REV** unit.

Datasheet		REV 020			REV 035			REV 050			REV 070		
		A	I	W	A	I	W	A	I	W	A	I	W
Dehumidifying capacity	L/Day	24,5	24,5	29	36	36	43	48	48	58	68	68	71
Nominal air flow	m³/h	260	260	260	380	380	380	520	520	520	700	700	700
Fresh air flow	m³/h	0 - 130	0 - 130	0 - 130	0 - 190	0 - 190	0 - 190	0 - 260	0 - 260	0 - 260	0 - 350	0 - 350	0 - 350
Heat recovery efficiency	%	> 90%											
Cooling capacity	W	Isothermal	1300	1920	Isothermal	2380	2700	Isothermal	3230	3650	Isothermal	4620	4290
Sound level	dB(A)	39	39	38	41	41	39	44	44	43	46	46	45
Power supply	V/ph/Hz	230 / 1~ +N / 50											
Dimensions W x D x H	mm	600 x 380 x 980			650 x 430 x 1050			700 x 515 x 1600			700 x 515 x 1600		
Weight	kg	60	60	50	65	65	55	90	90	75	92	92	77
Type of installation		Wall mounting			Wall mounting			Base mounting			Base mounting		

All the values refer to the following conditions: Air temperature 26°C, Relative Humidity 65%, Water temperature 15°C W Version: water at 10°C.

**The REV range consists of 3 versions: A – I – W**

**A = Neutral air version (isothermal):** The letter “A” represents a neutral air isothermal dehumidifier. The outlet air is at the same temperature as the inlet air.

**I = Cold integration version:** The letter “I” represents a dehumidifier that can add cold power to the radiant system. The “I” models cool the air as a normal air-conditioner, when required.

**W = Water version:** The letter “W” identifies an especially silent chilled water hydronic dehumidifier without compressor. The outlet air is always cooler than the inlet air. The “W” version supplies conditioned air in summer and heating in winter.

**Summer functions**

- Renewal
- Renewal + dehumidification
- Renewal + dehumidification + cooling
- Dehumidification
- Dehumidification + cooling
- Free-cooling

- 1 Fresh air intake
- 2 Exhaust air intake
- 3 Room air intake (for recirculation)
- 4 Exhaust air discharge
- 5 Room air supply
- 6 Heat exchange coil
- 7 Supply fan
- 8 Compressor
- 9 Exhaust fan
- 10 Heat recovery system
- 11 Recirculation damper
- 12 Supply air filter
- 13 Recovery system air filter
- 14 Outdoor air filter
- 15 Outdoor air damper (optional)

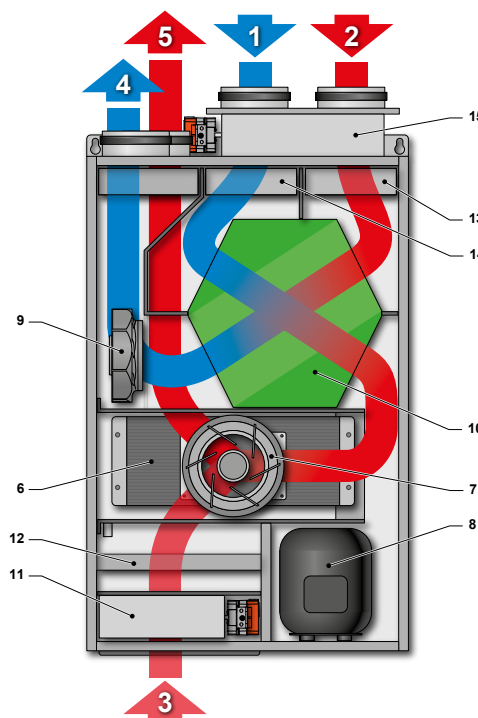

**Winter functions**

- Renewal
- Renewal + heating
- Heating
- Free-heating

**Included:**

- Color touch display with T/RH probes + 2 meters connection cable
- Modulating EC fan
- Filter: Recirculation class ISO Coarse 70% (G2) Outside air class ISO Coarse 70% (G2), Extraction class ISO Coarse 70% (G2)
- Serial board RS485 - Modbus
- Time bands program
- Multi-speed fresh air
- Timed signal for air filters check
- Boost mode for fresh air



**Options:**

- Color touch display with T/RH/IAQ probes and WiFi + 2 meters connection cable
- Outdoor air dampers for dew-point control
- Free-cooling
- ACF - Automatic Control Flow
- T/RH touch display connection cable of 5, 10 or 20 meters
- Temperature and humidity probes on board
- Enthalpic recuperator
- Filter class ISO Coarse 90% (G4), filter class ISO ePM10 80% (F7)
- T/RH probes on board
- Recovery automatic defrosting
- Serial board RS485 - Modbus
- Silent version
- Adjustable supply air temperature control
- Recirculation plenum
- Air distribution: see chapter AIR DISTRIBUTION

**RDE**

**HORIZONTAL AND VERTICAL POLYPROPYLENE  
HEAT RECOVERY UNIT**



**RDE 010  
RDE 018**



**RDE 020**



Air quality and purity, temperature and humidity are critical for comfort, especially during the winter when opening the windows for air results in a significant loss of heat and discomfort for the occupants.

In this case a system of controlled mechanical ventilation is the best solution to maintain both the levels of energy performance and the quality of the indoor air. Recent regulations on energy saving in buildings combined with increasingly efficient thermal insulation and ever-better fitting of doors and windows, have definitely made our homes more comfortable both thermally and acoustically, but this has also transformed them into potential “hazardous, sealed traps” where pollutants used in the production process (such as formaldehyde) can be spontaneous released.

To achieve adequate air renewal in the building and to ensure good indoor air quality, it is essential to install a controlled mechanical ventilation system.

Air renewal is essential for clean living air. The European Parliament has legislated on this, citing ventilation as a “need” for the building. This “need” can clash with the need to improve the building’s energy performance to reduce consumption to a minimum.

Controlled mechanical ventilation with **RDE** of HiDew heat recovery is the best solution to reduce the energy needs of a building and at the same time improve the healthiness of the spaces.

Datasheet		RDE 010	RDE 018	RDE 020	RDE 035
<b>Efficiency rate</b>		<b>A / A+</b>			
<b>Nominal air flow</b>	m³/h	100	180	200	350
<b>Heat recovery efficiency</b>	%	90	87	90	90
<b>Recovered heating power in winter (1)</b>	W	760	1320	1520	2576
<b>Recovered heating power in summer (2)</b>	W	240	420	525	533
<b>Maximum power absorbed (3)</b>	W	113	125	136	179
<b>Sound level</b>	dB(A)	43	45	50	50
<b>Power supply</b>	V / Ph / Hz	230 / 1~ +N / 50	230 / 1~ +N / 50	230 / 1~ +N / 50	230 / 1~ +N / 50
<b>Available static pressure @ maximum speed</b>	Pa	200	200	160	100
<b>Dimensions W x D x H</b>	mm	1090 x 560 x 230	1090 x 560 x 230	870 x 660 x 300	870 x 660 x 300
<b>Weight</b>	kg	13	13	19	20
<b>Nozzle diameter</b>	mm	125	125	160	160

(1) The efficiency and thermal power recovered in winter are declared with ambient air + 20° C 50% RH and outdoor air -5° C 80% RH.

(2) The heat output recovered in summer is declared with ambient air + 26° C 50% RH and outdoor air + 35° C 70% RH.

(3) Maximum total value, including the two fans and electronics.

	STANDARD CONTROL	ADVANCED CONTROL
Wall-mounted graphic control display with temperature sensor, complete with shielded connection cable L.2 m	-	OPTION
Wall-mounted graphic control display with temperature and humidity sensors, complete with screened connecting cable L.2 m	-	OPTION
3-speeds control	<b>INCLUDED</b>	-
Multi-speed control	-	<b>INCLUDED</b>
Turbo mode	-	<b>INCLUDED</b>
Time bands program	-	<b>INCLUDED</b>
Electronic fans with brushless motor and built-in inverter	<b>INCLUDED</b>	<b>INCLUDED</b>
Dirty filters timed signal	<b>INCLUDED</b>	<b>INCLUDED</b>
Fault signal	<b>INCLUDED</b>	<b>INCLUDED</b>
Smart automatic defrosting	<b>INCLUDED</b>	<b>INCLUDED</b>
Free-cooling	<b>INCLUDED</b>	<b>INCLUDED</b>
Serial board RS485 - Modbus	-	OPTION
High efficiency air filter set	OPTION	OPTION
Shielded display connection cable of 5, 10 or 20 meters	-	OPTION
CO2 probe	-	OPTION
Ioniser control	-	<b>INCLUDED</b>
Duct water coil	OPTION	OPTION
Outlet temperature control kit	-	OPTION

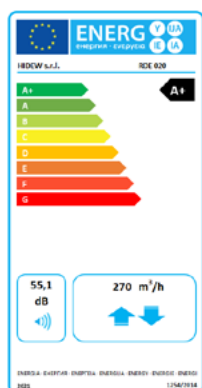

Sample of standard control (not supplied)



**Lightness**



**Efficiency**



**Quality**



**Installation flexibility**



**Easy maintenance**

### THE HEAT RECOVERY SYSTEMS:

- Increase efficiency class and property value
- Renew air without dispersing heat
- Reduce danger of allergies



**RCE**

**RFE**

**BUILT-IN VERTICAL HEAT RECOVERY UNITS**



**RCE 022**



**RFE 022**



Vertical built-in mechanical ventilation system, with high efficiency heat recovery unit.

The **RCE** model provides for the delivery to the ceiling while the **RFE** model provides for the delivery to the floor.

Both units guarantee a good air quality in the rooms, in addition to the indispensable air exchange in the building, that allow reducing consumption to a minimum.

Free-cooling, which is standard on RCE and RFE, increases the seasonal efficiency of the system.

Air quality, temperature and humidity are fundamental elements for comfort, especially during the winter period when the opening of windows to change the air involves a considerable dispersion of heat and discomfort for the occupants.

The European Parliament itself has legislated on the matter, citing ventilation as a “need” of the building.

This “need” clashes, however, with the need to improve the energy performance of buildings in order to minimize consumption.

The controlled mechanical ventilation with heat recovery **RCE** and **RFE** of HiDew is the best solution to reduce the energy needs of the house while improving the healthiness of the environment. The RCE and RFE series of very high efficiency recessed vertical heat recovery units are designed for use in residential and commercial environments, the latter being small in size.

The recessed vertical installation allows to reduce the thickness of the false ceiling, ensuring high performance.

Datasheet		RCE - RFE	
		016	022
Nominal air flow	m <sup>3</sup> /h	160	220
Efficiency (1)	%	90	90
Heat output recovered in winter (1)	W	1208	1662
Heat output recovered in summer (2)	W	416	572
Maximum absorbed power (3)	W	74	90
Maximum absorbed current (3)	A	1	1,5
Power supply	V / Ph / Hz	230 / 1~+N / 50	230 / 1~+N / 50
Available static pressure @ maximum speed	Pa	160	160
Storage temperature limit	°C	- 10 / + 43	- 10 / + 43
Storage humidity limit	% UR	90	90
Weight	kg	27	33

(1) The efficiency and heat output recovered in winter are indicated with room air +20°C 50% RH and outdoor air -5°C 80% RH.

(2) The heat output recovered in summer is indicated with room air +26°C 50% RH and outdoor air +35°C 70% RH.

(3) Maximum total value, including the two fans and the electronic devices.

	STANDARD CONTROL	ADVANCED CONTROL
Wall-mounted graphic display with temperature probe	-	OPTIONAL
Wall-mounted graphic display with temperature and humidity probe	-	OPTIONAL
3-speeds control	INCLUDED	-
Multi-speed adjustment	-	INCLUDED
Turbo mode	-	INCLUDED
Time bands program	-	INCLUDED
Electronic fans with brushless motor and built-in inverter	INCLUDED	INCLUDED
Dirty filter timed signal	INCLUDED	INCLUDED
Fault signal	INCLUDED	INCLUDED
Smart automatic defrosting	INCLUDED	INCLUDED
Free-cooling / free-heating	INCLUDED	INCLUDED
Serial board RS485 - Modbus	-	INCLUDED
High-efficiency air filters set	OPTIONAL	OPTIONAL
Shielded display connection cable of 5, 10 or 20 meters	-	OPTIONAL
CO2 probe	-	OPTIONAL
Ioniser control	-	INCLUDED

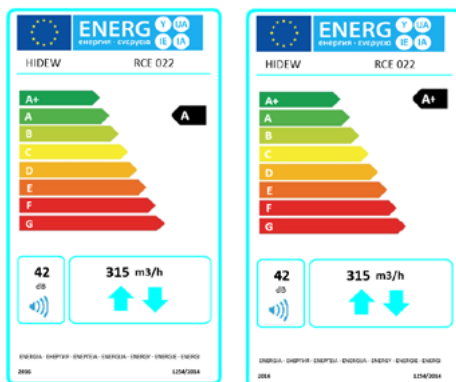

Sample of standard control (not supplied)



**Efficiency**



**Quality**

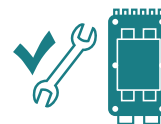

**Ease of installation and maintenance**

**THE HEAT RECOVERY SYSTEMS:**

- Increase efficiency class and property value
- Renew air without dispersing heat
- Reduce danger of allergies



**RCE UNIT INSTALLATION EXAMPLES:**

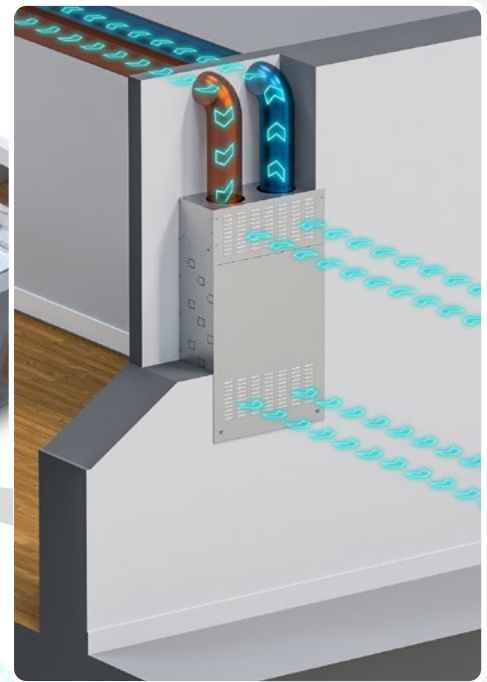
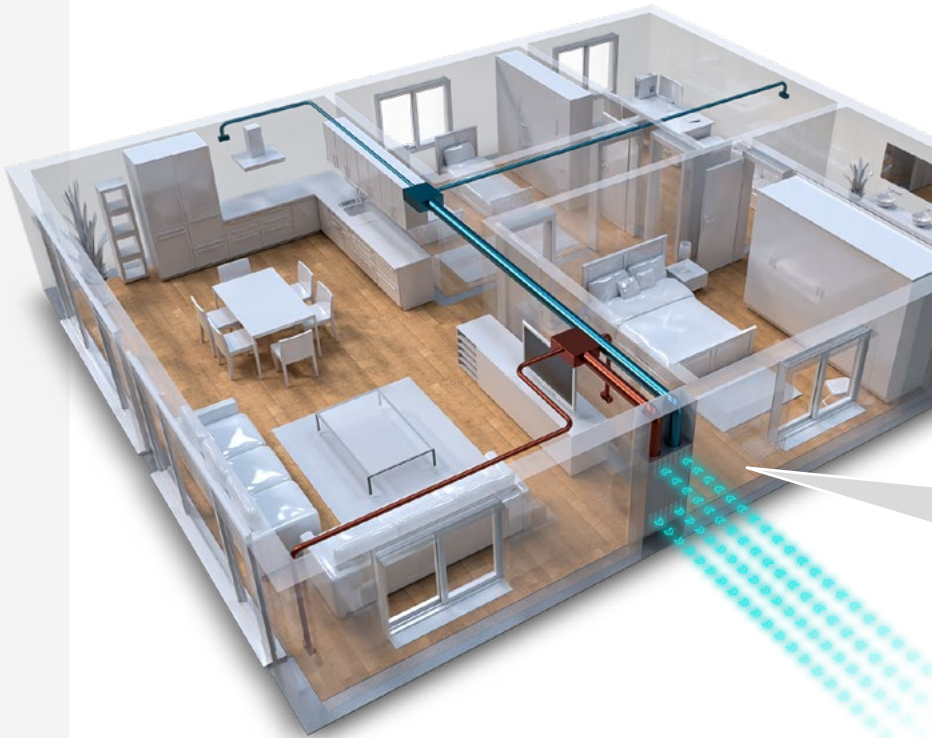

**RCE 022 – CASE WITH GALVANISED GRATING COVER WITHOUT NOZZLES**

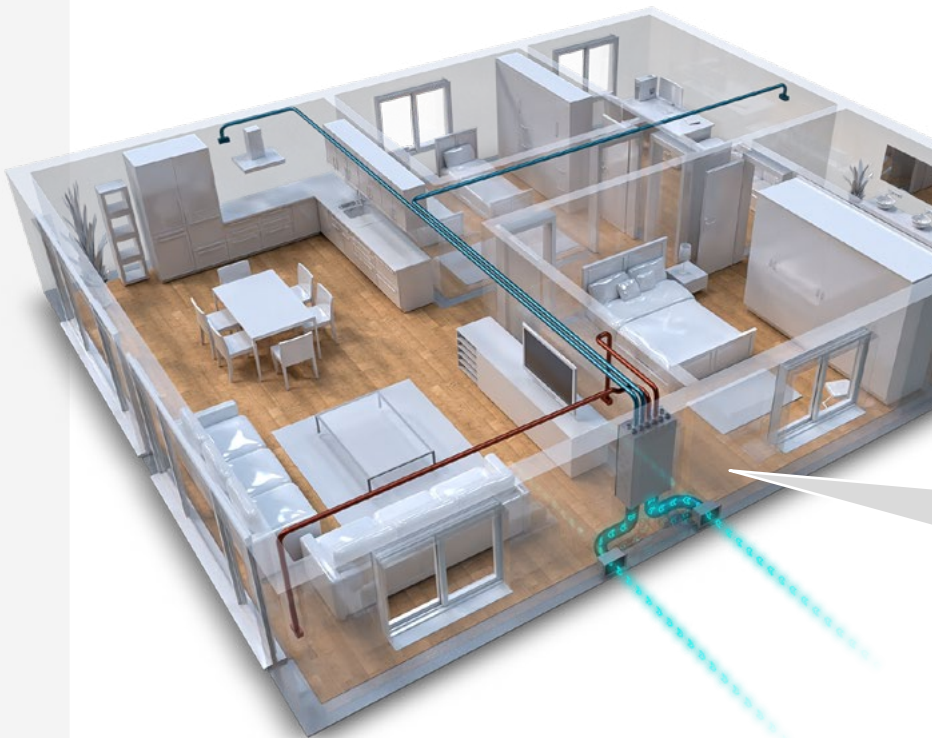

**RCE 022 – CASE WITH WHITE BLANK COVER WITH 6+6 PP NOZZLES**

**RFE UNIT INSTALLATION EXAMPLES:**

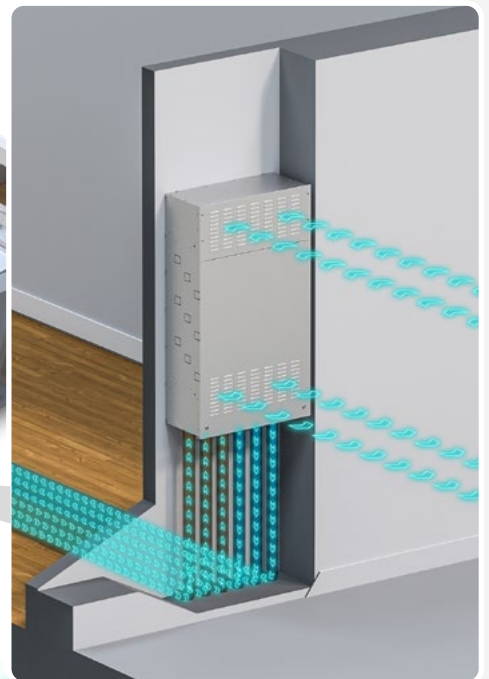
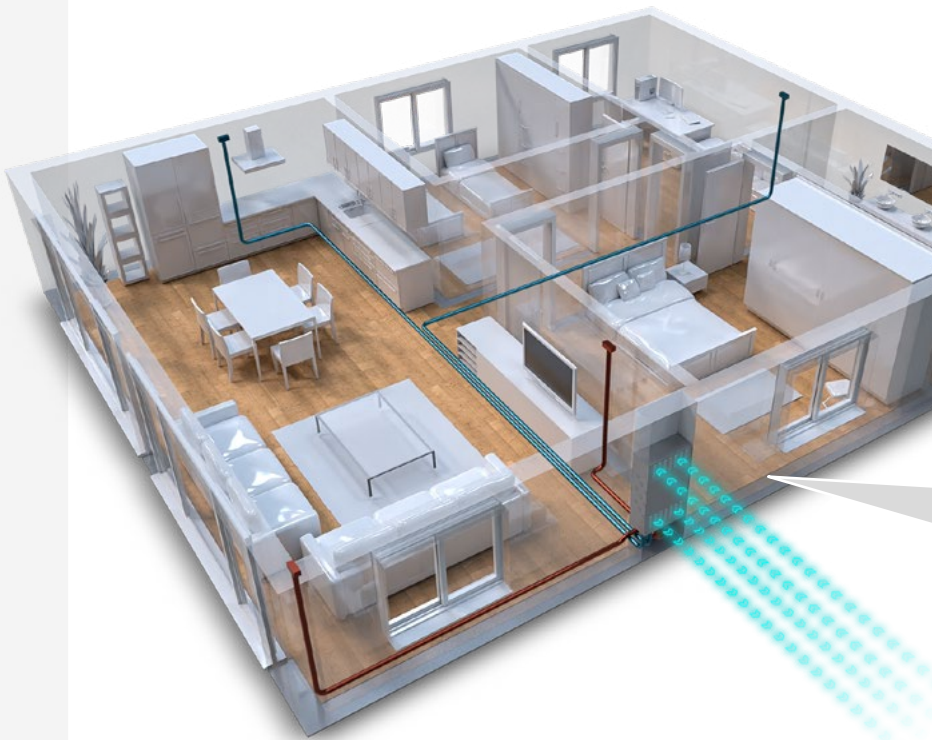

**RFE 022 – CASE WITH GALVANISED GRATING COVER WITH 6+6 PP NOZZLES**

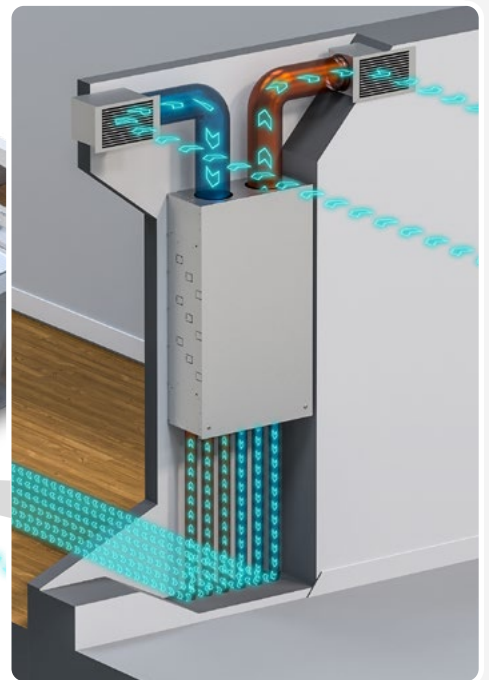
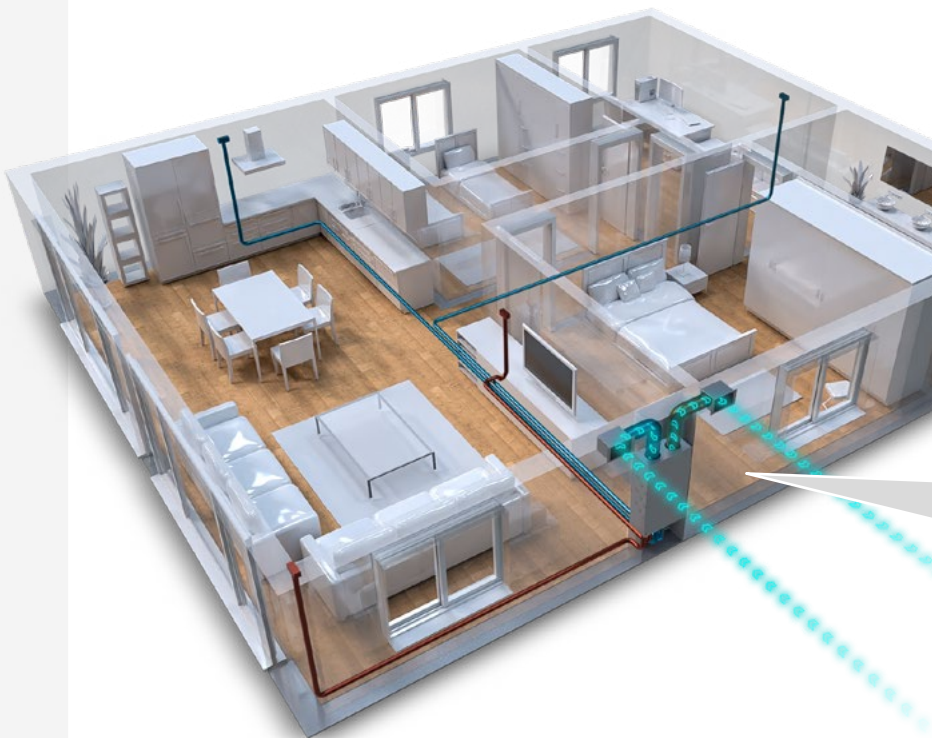

**RFE 022 – CASE WITH GALVANISED BLANK COVER WITH 6+6 PP NOZZLES**

**ROE**   **RVE**

**HEAT RECOVERY SYSTEMS**



**ROE 050**



**RVE 035**

HEAT RECOVERY  
 FREE COOLING  
 VARIABLE SPEED  
 AIR FILTERS  
 RS485 PROTOCOL CONNECTION LINK

Air quality and purity, temperature and humidity are critical for comfort, especially during the winter when opening the windows for air results in a significant loss of heat and discomfort for the occupants.

In this case a system of controlled mechanical ventilation is the best solution to maintain both the levels of energy performance and the quality of the indoor air.

Recent regulations on energy saving in buildings combined with increasingly efficient thermal insulation and ever-better fitting of doors and windows, have definitely made our homes more comfortable both thermally and acoustically, but this has also transformed them into potential “hazardous, sealed traps” where pollutants used in the production process (such as formaldehyde) can be spontaneous released.

To achieve adequate air renewal in the building and to ensure good indoor air quality, it is essential to install a controlled mechanical ventilation system.

Air renewal is essential for clean living air.

The European Parliament has legislated on this, citing ventilation as a “need” for the building.

This “need” can clash with the need to improve the building’s energy performance to reduce consumption to a minimum.

Controlled mechanical ventilation with **ROE** and **RVE** of HiDew heat recovery is the best solution to reduce the energy needs of a building and at the same time improve the healthiness of the spaces.

Datasheet		ROE		RVE	
		050		035	050
<b>Efficiency rate</b>		A / A+			
Nominal air flow	m³/h	500		350	500
Heat recovery efficiency	%	88		90	88
Recovered heating power in winter	W	3732		2660	3732
Recovered heating power in summer	W	1280		920	1280
Absorbed power consumption	W	85		75	85
Sound level	dB(A)	49		50	49
Power supply	V/ph/Hz	230 / 1~ +N / 50			
Available static pressure @ maximum speed	Pa	160		150	160
Dimensions W x D x H	mm	1094x730x400		510x700x860	510x700x860

The recovered heat power and efficiency values are stated in the indoor air 20°C / 50% RH and outdoor air -5°C / 80% RH points.

	STANDARD CONTROL	ADVANCED CONTROL
Wall-mounted graphic control display with temperature sensor, complete with shielded connection cable L.2 m	-	OPTION
Wall-mounted graphic control display with temperature and humidity sensors, complete with screened connecting cable L.2 m	-	OPTION
3-speed control	INCLUDED	-
Multi-speed control	-	INCLUDED
Turbo mode	-	INCLUDED
Time bands program	-	INCLUDED
Electronic fans with brushless motor and built-in inverter	INCLUDED	INCLUDED
Dirty filters timed signal	INCLUDED	INCLUDED
Fault signal	INCLUDED	INCLUDED
Smart automatic defrosting	INCLUDED	INCLUDED
Free-cooling	INCLUDED	INCLUDED
Serial board RS485 - Modbus	-	OPTION
High efficiency air filter set	OPTION	OPTION
Shielded display connection cable of 5, 10 or 20 meters	-	OPTION
CO2 probe	-	OPTION
Ioniser control	-	INCLUDED
Duct water coil	OPTION	OPTION
Outlet temperature control kit	-	OPTION



#### THE HEAT RECOVERY SYSTEMS:

- Increase efficiency class and property value
- Renew air without dispersing heat
- Reduce danger of allergies



**AER**

**AIR-TO-AIR UNIT FOR PASSIVE HOUSES  
WITH HEAT RECOVERY**

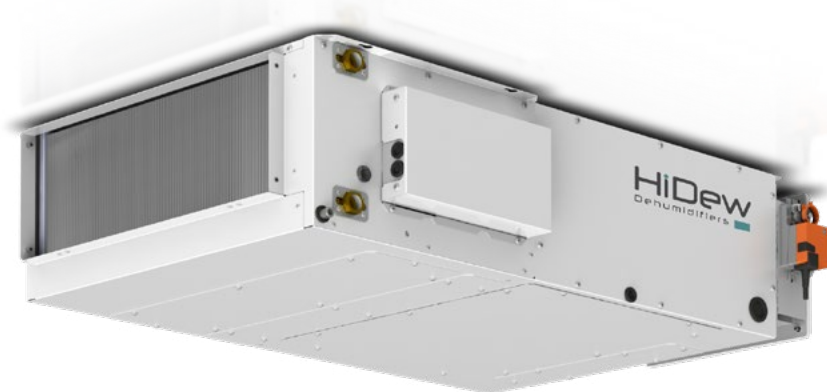

**AER 024**



**AER** units are the solution to the growing demand for heating and cooling systems for passive houses or buildings with limited energy loads. In such contexts, an air-to-air unit becomes the guarantor of comfort in the rooms, taking charge not only of maintaining the required air temperature but also the relative humidity and air quality.

AER units are also perfect for the all-round air conditioning of hotel rooms where individual and precise comfort is required, without any interference between guests.

Typically combined with high-efficiency heat pumps, but not only, the AER units are monobloc machines developed horizontally, perfect for installation in false ceilings or in technical rooms.

In addition to the water exchanger for heating or cooling the air, they are equipped with a counterflow heat recovery unit with efficiency of over 90% and a mixing chamber with 3 dampers for continuous modulation of the percentage of external air.

The fan sections consist of modern, maintenance-free, directly coupled EC radial fans.

Rotation speed control allows the air flow rate to be modulated according to the ambient loads, taking into account the need for quietness at night or peaks in demand due to crowding or particularly harsh external conditions.

**Data sheet**

		<b>AER 024</b>	<b>AER 036</b>	<b>AER 058</b>
<b>Efficiency rate</b>		<b>A / A+</b>		
<b>Heating capacity</b> ( min / nom / max ) (1)	kW	2.24 / 2.89 / 3.50	3.35 / 3.80 / 4.31	4.48 / 5.77 / 7.00
<b>Cooling capacity</b> ( min / nom / max ) (2)	kW	2.27 / 2.92 / 3.52	3.29 / 3.68 / 4.14	4.54 / 5.83 / 7.03
<b>Heat recovery efficiency</b>	%	> 93	> 93	> 93
<b>Nominal power</b>	W	72,5	89	90
<b>Power supply</b>	V / ph / Hz	230 / 1~ +N / 50	230 / 1~ +N / 50	230 / 1~ +N / 50
<b>Nominal flow water coil</b>	m³/h	0,5	0,7	1
<b>Nominal air flow</b>	m³/h	400	600	800
<b>Fresh air flow</b>	m³/h	0 - 120	0 – 180	0 - 240
<b>Maximum nominal available static pressure</b>	Pa	160	160	160
<b>Sound level</b> (3)	dB(A)	40	43	45
<b>Dimensions W x D x H</b>	mm	1125 x 680 x 250	1125 x 680 x 300	1545 x 810 x 350
<b>Weight</b>	kg	27	33	33

(1) Heating capacity is declared with ambient +20°C, 50% RH and with water +45°C.

(2) Cooling capacity is declared with ambient +27°C, 47% RH and with water +7°C.

(3) Sound pressure level measured in free field, 2 m from the unit, with a correction factor Q=2, according to the ISO 9614 standard, ducted unit with static pressure 50 Pa.

**Functions:**

- Air renewal with heat recovery
- Cooling
- Dehumidification
- Heating
- Free-cooling
- Free-heating

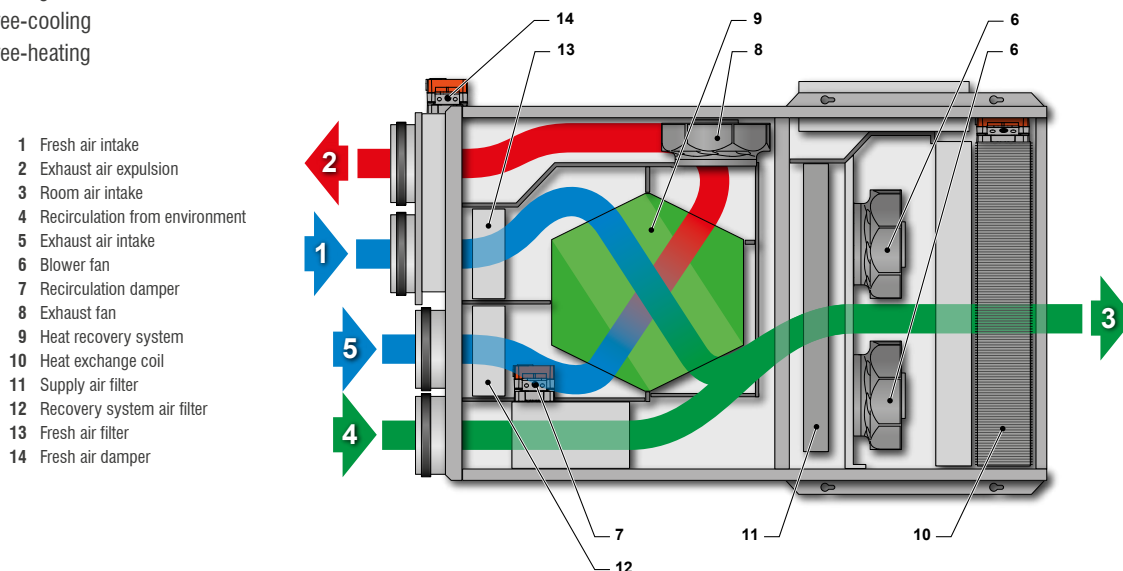

- 1 Fresh air intake
- 2 Exhaust air expulsion
- 3 Room air intake
- 4 Recirculation from environment
- 5 Exhaust air intake
- 6 Blower fan
- 7 Recirculation damper
- 8 Exhaust fan
- 9 Heat recovery system
- 10 Heat exchange coil
- 11 Supply air filter
- 12 Recovery system air filter
- 13 Fresh air filter
- 14 Fresh air damper

**ADVANCED CONTROL**

Electronic fans with brushless and inverter integrated	<b>INCLUDED</b>
Regulation graphic display with temperature and humidity probes and 2 metres of connecting shielded cable	<b>INCLUDED</b>
5 speeds regulation for fresh air	<b>INCLUDED</b>
Dirty filters timed signal	<b>INCLUDED</b>
Detailed fault signal	<b>INCLUDED</b>
Boost mode	<b>INCLUDED</b>
Time bands program	<b>INCLUDED</b>
Water anti-frost function	<b>INCLUDED</b>
Free cooling	<b>INCLUDED</b>
Recovery automatic defrosting	<b>INCLUDED</b>
Serial board RS485 - Modbus	<b>INCLUDED</b>
Shielded display connection cable of 5, 10 or 20 meters	⊙
Temperature and humidity probes mounted on board	<b>INCLUDED</b>
CO2 probe	⊙
Motorised dampers	<b>INCLUDED</b>
High-efficiency air filter set	⊙
Supply plenum	⊙
Electric preheater	⊙

⊙ Option available

## AIR DISTRIBUTION

## DEVICES FOR AIR DUCTING

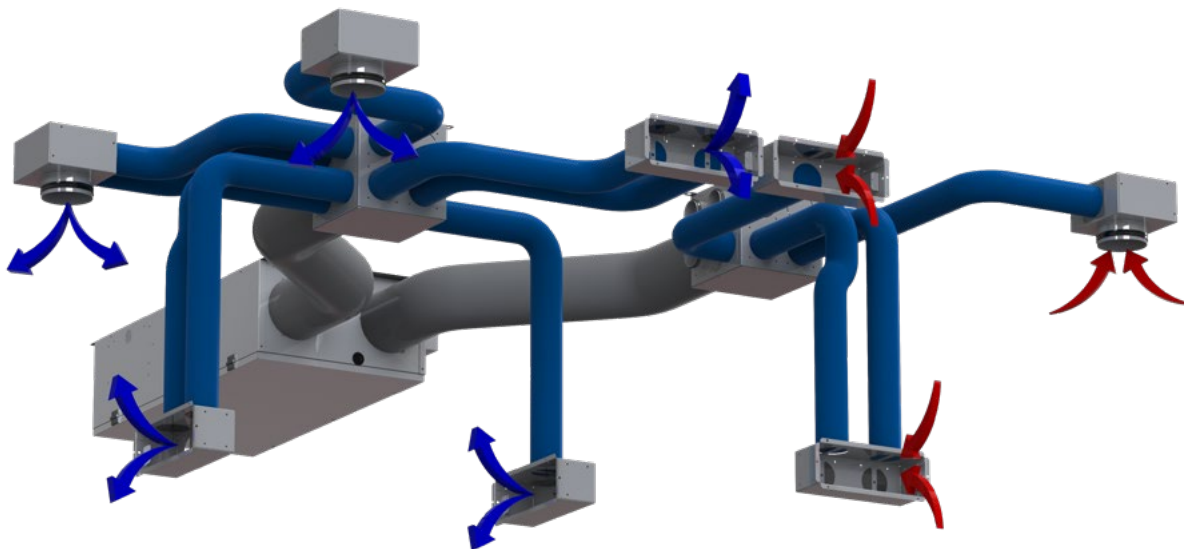

The new series of devices for air ducting for **AIR DISTRIBUTION**, to be combined with the units of our **RO, RS, RV, HO, RER, REV, RDE, RCE, RFE, ROE, RVE** and **AER** series.

Thanks to the variety and completeness of this line, it is possible to realize the ideal comfort conditions and to give an optimal response to the needs for the different installations and canalizations of the units.

Our supply and recovery plenums, the coils for ducted installations and the grilles, combined with our machines, grant the realization of flexible, complete and customizable systems for the air distribution, capable of satisfying the needs of each single ambient.



**The installation of  
HiDew  
devices for air ducting  
accessories  
is a child's play!**

**Accessories**

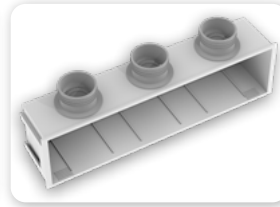
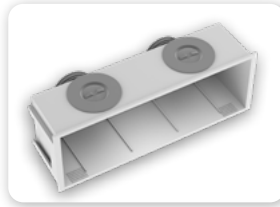
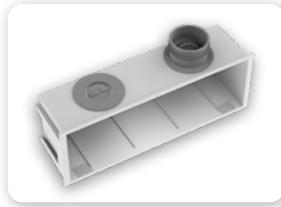

**NEW**

ABS Plenum 300 mm with 1-2 connections and 400 mm with 3 connections, equipped with air calibration valve.

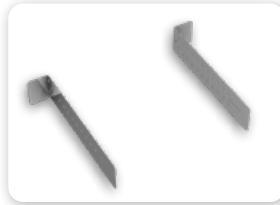
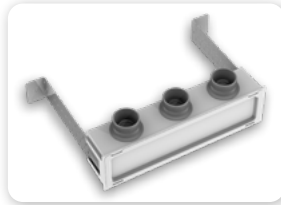

Adjustable metal brackets for 90°: 300 mm lengths.

Paintable ABS cover 300 and 400 mm.

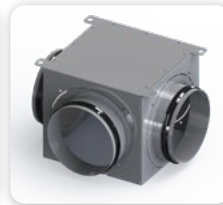
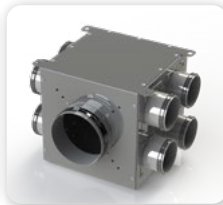
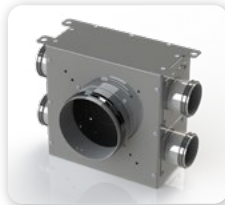

Supply and recover air galvanized steel plenums with internal thermal insulation and sound absorber, with circular connections.

"T" splitter plenum.

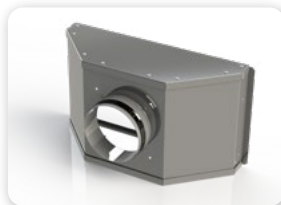

Conical supply plenum in galvanized steel with internal thermal insulation and sound absorber (for RER models).

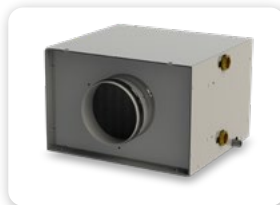

Hot / cold water coil ducted with galvanized steel plenum, internal insulation, sound absorber and steel basin for condensation collection.

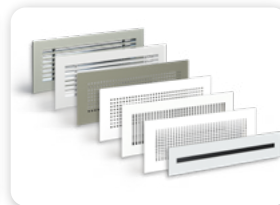

Intake and supply grilles with refined design, available in aluminium or brushed steel.

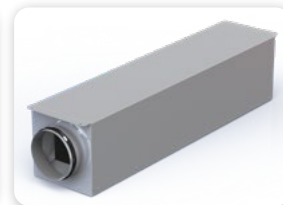

High performance silencer.

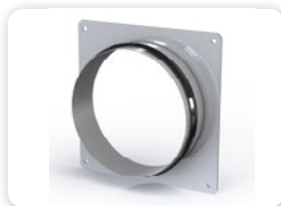

Flange for the connection of flexible pipes in / out air renewal.

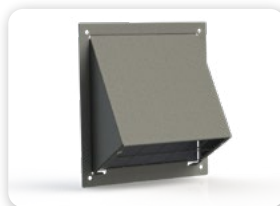

Outdoor grille in stainless steel.



Flexible pipe diameters mm. 125 / 160 / 180 / 200 / 250.



Polyethylene pipes for the canalization and distribution of air, to be combined with supply and recover plenums.

**HiDew**  
Dehumidifiers 

**HiDew S.r.l.**

Headquarter : Via dell'Artigianato, 5 35026 Conselve (PD) - Italy  
Phone: +39 049 9502511

Registered Office : Viale Spagna, 31/33 35020 Tribano (PD) - Italy  
Phone: +39 049 9588511 Fax: +39 049 9588522

[www.hidew.it](http://www.hidew.it) [info@hidew.it](mailto:info@hidew.it)



HD-R3EN-2025

MADE IN ITALY



HiDew S.r.l. reserves the right to change the specifications and other information contained herein without notice. No part of this publication may be reproduced without the prior written permission of HiDew S.r.l.